

DIAMOND 12

12 Series

走心式CNC自動車床“金鑽 12”系列

SWISS TYPE CNC AUTO LATHE



- 4支固定式內徑刀具刀座
4 PCS I.D. STATIONARY TOOLS HOLDER



- 6支外徑刀具刀座
6 PCS O.D. TURNING TOOLS HOLDER



POLY GIM

SIMPLICITY • PRECISION • SPEED • DURABILITY • STABILITY

機械規格 MACHINE SPECIFICATIONS :

ITEMS	機型	DIAMOND 12	DIAMOND 12CS	DIAMOND 16	DIAMOND 16CS
加工範圍 Working Range	最大加工外徑 Max. turning dia.	Ø12.7mm	Ø12.7mm	Ø16.5mm	Ø16.5mm
	最大加工長度 Max. turning length	150mm	150mm	150mm	150mm
	最大鑽孔直徑 Max. drilling dia.	Ø7mm	Ø7mm	Ø10mm	Ø10mm
	最大攻牙直徑 Max. tapping dia.	M6	M6	M8	M8
外徑刀 O.D. Tooling	刀具數 Number of tools	6	6	6	6
	刀具尺寸 Dimension	□10X10X100	□10X10X100	□10X10X100	□10X10X100
內徑刀 I.D. Tooling	刀具數 Number of tools	4	4	4	4
	刀具尺寸 Dimension	7mm (ER11)	7mm (ER11)	10mm (ER16)	10mm (ER16)
側面鑽銑刀 Cross working driven tooling	刀具數 Number of tools	—	4	—	4
	刀具尺寸 Dimension	—	7mm (ER11)	—	10mm (ER16)
	刀具轉速 Cross spindle speed	—	200~6,000rpm	—	200~6,000rpm
正面鑽銑刀 Front working driven tooling	刀具數 Number of tools	—	3	—	3
	刀具尺寸 Dimension	—	7mm (ER11)	—	10mm (ER16)
	刀具轉速 Spindle speed	—	6,000rpm	—	6,000rpm
主軸 Spindle	主軸內徑 Spindle hole dia.	Ø13mm	Ø13mm	Ø17mm	Ø17mm
	主軸轉速 Spindle Speed	200~12,000rpm	200~12,000rpm	200~12,000rpm	200~12,000rpm
快速位移	Rapid speed	30M	30M	30M	30M
馬達 Motors	主軸馬達 Spindle Motor	2.2kw	2.2kw	3.7kw	3.7kw
	X/Y/Z軸馬達 X/Y/Z Axis Motor	0.75kw	0.75kw	0.75kw	0.75kw
	切削馬達 Coolant Pump	0.18kw	0.18kw	0.18kw	0.18kw
	潤滑油馬達 Lubrication	4w	4w	4w	4w
	側銑馬達 Cross Spindle	—	0.4kw	—	0.4kw
	總電源容量 Total Power	4.634kw	5.034kw	6.134kw	6.534kw
	機械尺寸 Machine Dimensions	主軸中心高 Center Height	1050mm	1050mm	1050mm
氣壓 Air	重量 Weight	1088kg	1098kg	1120kg	1125kg
	機械尺寸 Machine Size	1200x900x1750	1200x900x1750	1200x900x1750	1200x900x1750
空氣壓力 Air Pressure	空氣壓力 Air Pressure	5kg/cm	5kg/cm	5kg/cm	5kg/cm
	空氣量 Air Supply	10L/min	10L/min	10L/min	10L/min

●因長期研發，機械設計如有變更恕不另行通知。 We reserve the right to change the above design without prior notification.

機械配件 MACHINE ACCESSORIES :

項目 ITEMS	DIAMOND 12	DIAMOND 12CS	DIAMOND 16	DIAMOND 16CS
主軸5°定位 Spindle 5° indexing	—	●	—	●
工件切斷檢測 Part off detective sensor	●	●	●	●
冷卻系統 Coolant system	●	●	●	●
工作燈 Working light	●	●	●	●
收料器 Part catcher	●	●	●	●
鐵屑盒 Chip tray	●	●	●	●
固定式套筒 Fixed bushing	●	●	●	●
側銑刀具刀座 Cross working driven tool holder	—	●	—	●
正面偏心鑽銑刀具刀座 Front off-center driven tool holder	—	●	—	●
粗料套筒 Rough material bushing	●	●	●	●
同期迴轉套筒 Live Bushing	●	●	●	●

● 標準配備 Standard ● 選購配備 Option — 無 N/A

■ 內藏式馬達 Built-in Type Motor



刀具圖 : DIAMOND 12/16 : TOOL HOLDER (A)
DIAMOND 12CS/16CS: TOOL HOLDER (A+B)

TOOL HOLDER (A)

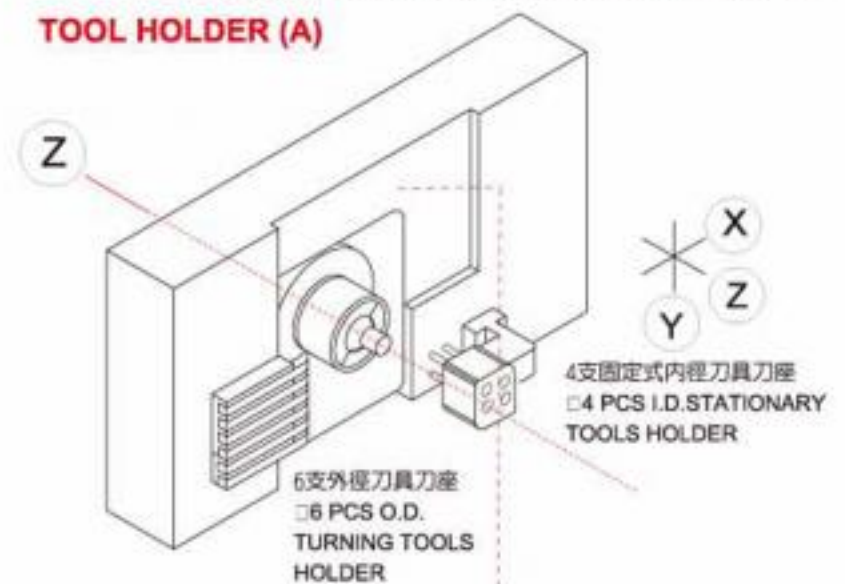

TOOL HOLDER (B)



POLY GIM

富格蘭科技有限公司
POLY GIM MACHINERY CO., LTD.

苗栗縣銅鑼鄉竹森村149之1號

No. 149-1, Zhusen Village, Tongluo Shiang, Miao-Li Country 366, Taiwan

TEL: 886-37-981220 • 980599 FAX: 886-37-985306

E-Mail: polygim@ms69.hinet.net Web://www.polygim.com.tw